

CIO-DAS08-PGH

CIO-DAS08-PGM

CIO-DAS08-PGL

Analog Input & Digital I/O



**MEASUREMENT
COMPUTING™**

Revision 9
October, 2000

LIFETIME WARRANTY

Every hardware product manufactured by Measurement Computing Corp. is warranted against defects in materials or workmanship for the life of the product, to the original purchaser. Any products found to be defective will be repaired or replaced promptly.

LIFETIME HARSH ENVIRONMENT WARRANTY™

Any Measurement Computing Corp. product which is damaged due to misuse may be replaced for only 50% of the current price. I/O boards face some harsh environments, some harsher than the boards are designed to withstand. When that happens, just return the board with an order for its replacement at only 50% of the list price. Measurement Computing Corp. does not need to profit from your misfortune. By the way, we will honor this warranty for any other manufacture's board that we have a replacement for!

30 DAY MONEY-BACK GUARANTEE

Any Measurement Computing Corp. product may be returned within 30 days of purchase for a full refund of the price paid for the product being returned. If you are not satisfied, or chose the wrong product by mistake, you do not have to keep it. Please call for a RMA number first. No credits or returns accepted without a copy of the original invoice. Some software products are subject to a repackaging fee.

These warranties are in lieu of all other warranties, expressed or implied, including any implied warranty of merchantability or fitness for a particular application. The remedies provided herein are the buyer's sole and exclusive remedies. Neither Measurement Computing Corp., nor its employees shall be liable for any direct or indirect, special, incidental or consequential damage arising from the use of its products, even if Measurement Computing Corp. has been notified in advance of the possibility of such damages.

MEGA-FIFO, the CIO prefix to data acquisition board model numbers, the PCM prefix to data acquisition board model numbers, PCM-DAS08, PCM-D24C3, PCM-DAC02, PCM-COM422, PCM-COM485, PCM-DMM, PCM-DAS16D/12, PCM-DAS16S/12, PCM-DAS16D/16, PCM-DAS16S/16, PCI-DAS6402/16, Universal Library, *InstaCal*, *Harsh Environment Warranty* and Measurement Computing Corp. are registered trademarks of Measurement Computing Corp.

IBM, PC, and PC/AT are trademarks of International Business Machines Corp. Windows is a trademark of Microsoft Corp. All other trademarks are the property of their respective owners.

Information furnished by Measurement Computing Corp. is believed to be accurate and reliable. However, no responsibility is assumed by Measurement Computing Corp. neither for its use; nor for any infringements of patents or other rights of third parties, which may result from its use. No license is granted by implication or otherwise under any patent or copyrights of Measurement Computing Corp.

All rights reserved. No part of this publication may be reproduced, stored in a retrieval system, or transmitted, in any form by any means, electronic, mechanical, by photocopying, recording or otherwise without the prior written permission of Measurement Computing Corp.

Notice

Measurement Computing Corp. does not authorize any Measurement Computing Corp. product for use in life support systems and/or devices without the written approval of the President of Measurement Computing Corp. Life support devices/systems are devices or systems which, a) are intended for surgical implantation into the body, or b) support or sustain life and whose failure to perform can be reasonably expected to result in injury. Measurement Computing Corp. products are not designed with the components required, and are not subject to the testing required to ensure a level of reliability suitable for the treatment and diagnosis of people.

© Copyright 2000 Measurement Computing Corp.

TABLE OF CONTENTS

1: INTRODUCTION	1
1.1 SOFTWARE INSTALLATION	1
1.2 HARDWARE INSTALLATION	2
2: SIGNAL CONNECTION	4
2.1 CONNECTOR DIAGRAM	4
2.2 DIFFERENTIAL INPUTS	4
2.3 DIGITAL OUTPUTS & INPUTS	4
3: ANALOG CONNECTIONS	5
3.1 ANALOG INPUTS	5
3.2 WIRING CONFIGURATIONS	9
4: REGISTER ARCHITECTURE	13
4.1 CONTROL & DATA REGISTERS	13
4.2 A/D DATA REGISTER	14
4.3 STATUS AND CONTROL REGISTER	14
4.4 PROGRAMMABLE GAIN REGISTER	15
4.5 COUNTER LOAD & READ REGISTERS	17
4.6 COUNTER CONTROL REGISTER	17
4.7 COUNTER/TIMER	18
4.8 DIGITAL INPUT	19
4.9 DIGITAL OUTPUT	19
4.10 TRIGGER & INTERRUPT LOGIC	20
5: SPECIFICATIONS	21

This page is blank

1: INTRODUCTION

There are three versions of the CIO-DAS08-PGx board, CIO-DAS08-PGL, CIO-DAS08-PGH and CIO-DAS08-PGM. (The CIO-DAS08-PGM duplicates MetraByte DAS-8PGA ranges and codes). These versions will be referred to as CIO-DAS08-PGx throughout this manual except where the differences between the versions require specifying a particular version.

If you have one of these boards and are not sure which one, you can identify the -PGH or -PGL versions by noting the part number of the amplifier. The amplifier, U6, is located approximately in the center of the board. The part number of the amplifier on the -PGH version is PGA202. The part number of the amplifier on the -PGL version is PGA203. Call the factory for aid in identifying the -PGM version.

The CIO-DAS08-PGx boards are an extension of the popular CIO-DAS08 architecture. The boards are identical at the register level, performance, and connector, with the following exceptions:

1. Gains are programmable as follows:
 - a. CIO-DAS08-PGM gains are 0.5, 1, 10, 100, and 500.
 - b. CIO-DAS08-PGH gains are 0.5, 1, 5, 10, 50, 100, 500, and 1000.
 - c. CIO-DAS08-PGL gains are 0.5, 1, 2, 4, and 8.
2. Analog inputs are differential. (However, provision has been made to add resistors to convert the inputs to pseudo-single-ended mode.) To maintain compatibility with signal conditioning boards such as the CIO-EXP16, an optional SIP resistor provides ground reference to the CH# Low inputs.
3. A stable crystal (“XTAL”) oscillator provides the A/D pacer clock pulse. To give compatibility with programs written for the AD08, a jumper selects either the stable XTAL or the PC Bus clock.
4. A DC/DC converter supplies stable $\pm 15\text{VDC}$ power to the analog circuitry. The board can be ordered without the DC/DC converter. This reduces the cost but limits the ranges of analog inputs. It is available only on orders of ten or more units.
5. There is only one connector on the board.

1.1 SOFTWARE INSTALLATION

Before you open your computer and install the board, install and run *InstaCal*, the installation, calibration and test utility included with your board. *InstaCal* will guide you through switch and jumper settings for your board. Detailed information regarding these settings can be found below. Refer to the *Software Installation* manual for *InstaCal* installation instructions.

1.2 HARDWARE INSTALLATION

1.2.1 Base Address

The base address of the CIO-DAS08-PGx is set by switching a bank of DIP switches on the board (Figure 1-1). This bank of switches is labeled ADDRESS and numbered 9 to 3.

Ignore the word ON and the numbers printed on the switch

The switch works by adding up the weights of individual switches to make a base address. A 'weight' is active when the switch is down. Shown here, switches 9 and 8 are down, all others are up. Weights 200H and 100H are active, equaling 300H base address. The board is shipped with this default address selected. If this address is already in use on your computer, select a different address.

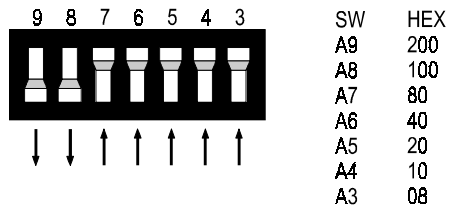

BASE ADDRESS SWITCH - Address 300H shown here.

Figure 1-1. Base address Select Switches

Table 1-1 lists the address ranges for the PC computer.

Table 1-1. Base Addresses

HEX RANGE	FUNCTION	HEX RANGE	FUNCTION
000-00F	8237 DMA #1	2C0-2CF	EGA
020-021	8259 PIC #1	2D0-2DF	EGA
040-043	8253 TIMER	2E0-2E7	GPIB (AT)
060-063	8255 PPI (XT)	2E8-2EF	SERIAL PORT
060-064	8742 CONTROLLER (AT)	2F8-2FF	SERIAL PORT
070-071	CMOS RAM & NMI MASK (AT)	300-30F	PROTOTYPE CARD
080-08F	DMA PAGE REGISTERS	310-31F	PROTOTYPE CARD
0A0-0A1	8259 PIC #2 (AT)	320-32F	HARD DISK (XT)
0A0-0AF	NMI MASK (XT)	378-37F	PARALLEL PRINTER
0C0-0DF	8237 #2 (AT)	380-38F	SDLC
0F0-0FF	80287 NUMERIC CO-P (AT)	3A0-3AF	SDLC
1F0-1FF	HARD DISK (AT)	3B0-3BB	MDA
200-20F	GAME CONTROL	3BC-3BF	PARALLEL PRINTER
210-21F	EXPANSION UNIT (XT)	3C0-3CF	EGA
238-23B	BUS MOUSE	3D0-3DF	CGA
23C-23F	ALT BUS MOUSE	3E8-3EF	SERIAL PORT
270-27F	PARALLEL PRINTER	3F0-3F7	FLOPPY DISK
2B0-2BF	EGA	3F8-3FF	SERIAL PORT

1.2.2 Interrupt Level Select

The interrupt jumper need only be set if the software you are using requires it. If you do set the interrupt jumper, please check your PC's current configuration for interrupt conflicts, and do not use IR2 in PC/AT class machines (or higher).

There is a jumper block on the CIO-DAS08-PGx located just above the PC bus interface (gold pins). The factory default setting is that no interrupt level is set. The jumper is in the 'X' position (Figure 1-2).

If you need to pace conversions through hardware (either the on - board pacer or an external clock), move this jumper to one of the other positions (see table 1-2).

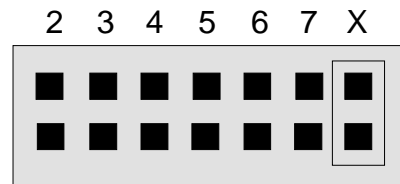

INTERRUPT JUMPER BLOCK - Jumper in X position = No IRQ.

Figure 1-2. Interrupt Select Jumper Block

The following table shows some typical interrupt assignments on a PC. The CIO-DAS08-PGx use interrupt levels 2 through 7. The levels most often available are 5 and 7.

Table 1-2. IRQ Assignments

NAME	DESCRIPTION	NAME	DESCRIPTION
NMI	PARITY	IRQ8	REAL TIME CLOCK (AT)
IRQ0 (AT)	TIMER	IRQ9	RE-DIRECTED TO IRQ2
IRQ1	KEYBOARD	IRQ10	UNASSIGNED
IRQ2	RESERVED (XT) INT 8-15 (AT)	IRQ11	UNASSIGNED
IRQ3	COM OR SDLC	IRQ12	UNASSIGNED
IRQ4	COM OR SDLC	IRQ13	80287 NUMERIC CO-P
IRQ5	HARD DISK (XT) or LPT (AT)	IRQ14	HARD DISK
IRQ6	FLOPPY DISK	IRQ15	UNASSIGNED
IRQ7	LPT		

NOTE: IRQ8-15 are AT only.

1.2.3 XTAL/PC Bus Clock Jumper

The A/D pacer clock sources for the MetraByte DAS-8PGA differs from the DAS-8. The source for the DAS-8PGA is fixed at 1 MHz while the source for the DAS-8 gets its clock pulse from the PC Bus Clock.

The CIO-DAS08-PGx pacer clock is selected by jumper to satisfy software written for either board (Figure 1-3). The default choice for this jumper is the 1 MHz position. You can alternately select the PC Bus Clock as the source for the A/D pacer clock.

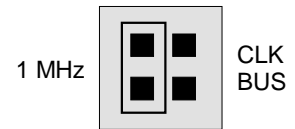

CLOCK SOURCE JUMPER - For a standard DAS-8PGA 1 MHz A/D Pacer Clock, place the jumper on the two leftmost pins. For a DAS-8 type A/D Pacer from PC Bus Clk, place the jumper on the two rightmost pins.

Figure 1-3. Pacer Clock Select Jumper

1.2.4 Wait State

A wait state can be enabled on the CIO-DAS08-PGx by selecting WAIT STATE ON at the jumper provided on the board. Enabling the wait state causes the personal computer's bus transfer rate to slow down for board reads and writes ..

The wait state jumper is provided in case your computer ever has an I/O bus transfer rate which is too fast for the CIO-DAS08-PGA. If your board were to fail sporadically in random ways, try selecting the wait state ON.

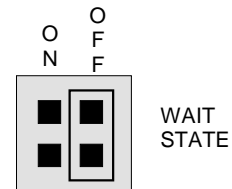

WAIT STATE JUMPER BLOCK - A wait state is not selected on this jumper block. For a wait state, place the jumper on the two leftmost pins.

Figure 1-4. Wait State Jumper Block

1.2.5 Installing The CIO-DAS08-PGx In The Computer

1. Turn the power off.
2. Remove the cover of your computer. Please be careful not to dislodge any of the cables installed on the boards in your computer as you slide the cover off.
3. Locate an empty expansion slot in your computer.
4. Push the board firmly down into the expansion bus connector. If it is not seated fully it may fail to work and could short circuit the PC bus power onto a PC bus signal. This could damage the motherboard in your PC as well as the board.

2: SIGNAL CONNECTION

2.1 CONNECTOR DIAGRAM

The analog connector is a 37-pin, D-type connector accessible from the rear of the PC through the expansion backplate (Figure 2-1).

The connector accepts female 37 D-type connectors, such as those on the C73FF-2, 2 foot cable with connectors.

If frequent changes to signal connections or signal conditioning is required, please refer to the information on the CIO-TERMINAL and CIO-MINI37 screw terminal boards, CIO-EXP32, 32 channels analog MUX/AMP. Isolation amplifiers can be mounted using the ISO-RACK08 and 5B isolation modules.

2.2 DIFFERENTIAL INPUTS

Differential inputs are 3-wire analog hookups consisting of a signal high, signal low and chassis ground. The benefits of differential inputs are the ability to reject noise which affects both signal high and low, and the ability to compensate for ground loops or potentials between signal low and chassis ground.

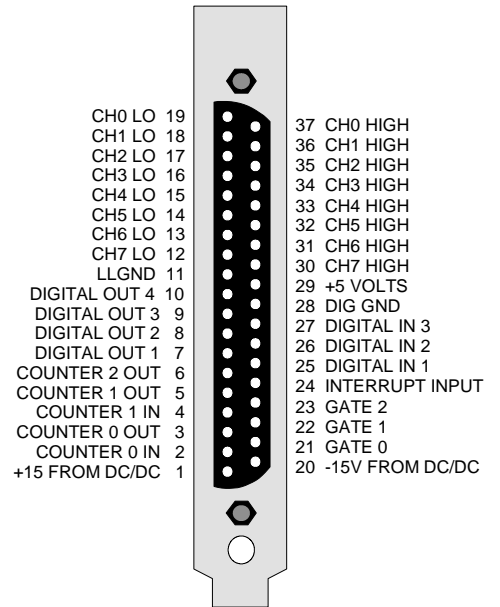

Figure 2-1. Analog Connector

Although differential inputs are often preferable to single ended inputs, there are occasions when the floating nature of a differential input can confound attempts to make a reading. In those cases, the inputs can be converted to modified differential.

Examine the diagram of the CIO-DAS08-PGx board. Near the 37-pin connector is located a position for an optional Single Inline Package (SIP) of resistors. Installing the SIP converts the analog inputs from fully differential to modified differential with a resistive reference to ground. A SIP resistor network is included with the board for this purpose.

NOTE: When using the CIO-DAS08-PGx with the CIO-EXP16 or CIO-EXP32, the optional SIP resistor must be installed. The CIO-EXP16 and CIO-EXP32 (and MetraByte EXP16) were designed to interface to a single-ended input. Failure to install the SIP resistor when the board is used with these expansion boards will result in floating, unstable readings.

Special instructions and solder are packaged with the SIP resistor. Follow the installation instructions carefully and use the solder provided. Use of any other solder, or failure to follow instructions can result in a degradation of the analog input's accuracy and may require out-of-warranty repair.

2.3 DIGITAL OUTPUTS & INPUTS

All the digital outputs inputs on the CIO-DAS08-PGx are TTL level. TTL is an electronics industry term, short for Transistor Transistor Logic, with describes a standard for digital signals which are either at 0V or 5V.

3.1 ANALOG INPUTS

Prior to jumping into actual connection schemes, you should have at least a basic understanding of Single-Ended/Differential inputs and system grounding/isolation. If you are already comfortable with these concepts you may wish to skip to the next section (on wiring configurations).

3.1.1 Single-Ended and Differential Inputs

The CIO-DAS08-PGx provides either 8 differential or 16 single-ended input channels. The concepts of single-ended and differential inputs are discussed in the following section.

Single-Ended Inputs

A single-ended input measures the voltage between the input signal and ground. In this case, in single-ended mode the CIO-DAS08-PGx measures the voltage between the input channel and LLGND. The single-ended input configuration requires only one physical connection (wire) per channel and allows the board to monitor more channels than the differential configuration using the same connector and onboard multiplexer (Figure 3-1). However, since the CIO-DAS08-PGx is measuring the input voltage relative to its own low level ground, single-ended inputs are more susceptible to both EMI (electro magnetic interference) and any ground noise at the signal source. The following diagrams show the single-ended input configuration. Note: For simplicity, the input multiplexer is not shown.

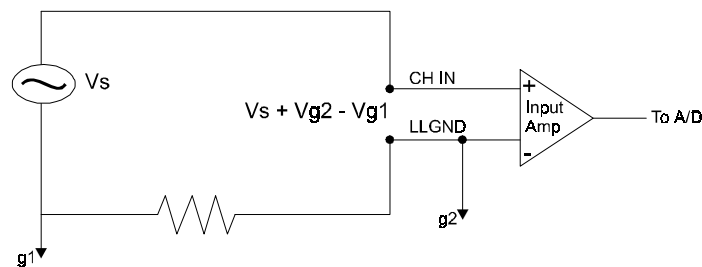
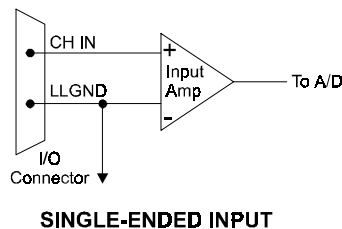

SINGLE-ENDED INPUT WITH COMMON MODE VOLTAGE - Any voltage differential between grounds g_1 and g_2 shows up as an error signal at the input amplifier.

Figure 3-1. Single-Ended Input Configuration (Simplified)

3.1.2 Differential Inputs

Differential inputs measure the voltage between two distinct input signals. Within a certain range (referred to as the common mode range), the measurement is almost independent of signal source to CIO-DAS08-PGA ground variations. A differential input is also much more immune to EMI than a single-ended one. Most EMI noise induced in one lead is also induced in the other, the input only measures the difference between the two leads, and the EMI common to both is ignored. This effect is a major reason there is twisted pair wire as the twisting assures that both wires are subject to virtually identical external influence. Figure 3-2 below shows a typical differential input configuration.

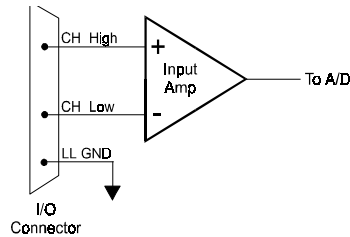

DIFFERENTIAL INPUT

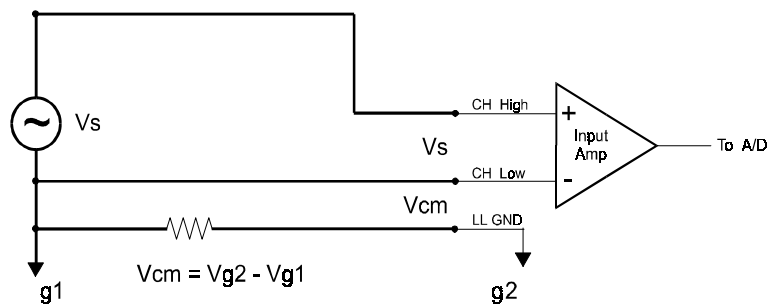

DIFFERENTIAL INPUT - Common Mode Voltage (V_{cm}) is ignored by differential input configuration. However, note that $V_{cm} + V_s$ must remain within the amplifier's common mode range of $\pm 10V$.

Figure 3-2. Differential Input Configuration

Before moving on to the discussion of grounding and isolation, it is important to explain the concepts of common mode, and common mode range (CM Range). Common mode voltage is depicted in Figure 3-2 as V_{cm} . Though differential inputs measure the voltage between two signals, without (almost) respect to the either signal's voltages relative to ground, there is a limit to how far away from ground either signal can go. Though the CIO-DAS08-PGx has differential inputs, it will not measure the difference between 100V and 101V as 1 Volt (in fact the 100V would destroy the board!). This limitation or common mode range is depicted graphically in Figure 3-3. The CIO-DAS08-PGx common mode range is ± 10 Volts. Even in differential mode, no input signal can be measured if it is more than 10V from the board's low level ground (LLGND).

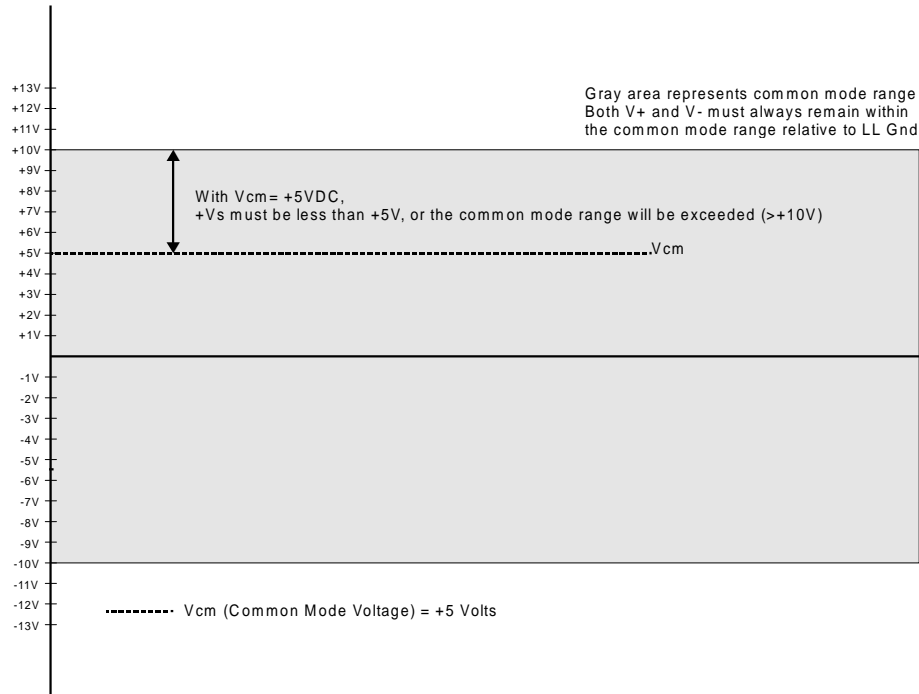

Figure 3-3. Common Mode Range Limits

3.1.3 System Grounds and Isolation

There are three scenarios possible when connecting your signal source to your board.

1. The board and the signal source may have the same (or common) ground. This signal source can be connected directly to the board.
2. The board and the signal source may have an offset voltage between their grounds (AC and/or DC). This offset is commonly referred to as a common mode voltage. Depending on the magnitude of this voltage, it may or may not be possible to connect the board directly to your signal source. We will discuss this topic further in a later section.
3. The board and the signal source may already have isolated grounds. This signal source may be connected directly to the board.

3.1.4 Which system do you have?

Try the following experiment. Using a battery powered voltmeter¹, measure the voltage (difference) between the ground signal at your signal source and at your PC. Place one voltmeter probe on the PC ground and the other on the signal source ground. Measure both the AC and DC Voltages.

If both AC and DC readings are 0.00 volts, you may have a system with common grounds. However, since voltmeters will average out high frequency signals, there is no guarantee. Please refer to the section below titled Common Grounds.

¹ If you do not have access to a voltmeter, skip the experiment and take a look at the following three sections. You may be able to identify your system type from the descriptions provided.

If you measure reasonably stable AC and DC voltages, your system has an offset voltage between the grounds category. This offset is referred to as a Common Mode Voltage. Please be careful to read the following warning and then proceed to the section describing Common Mode systems.

WARNING

If either the AC or DC voltage is greater than 10 volts, do not connect the CIO-DAS08-PGA to this signal source. You are beyond the boards usable common mode range and will need to either adjust your grounding system or add special Isolation signal conditioning to take useful measurements. A ground offset voltage of more than 30 volts will likely damage the board and possibly your computer. Note that an offset voltage much greater than 30 volts will not only damage your electronics, but it can also be hazardous to your health.

If you cannot obtain a reasonably stable DC voltage measurement between the grounds, or the voltage drifts around considerably, the two grounds are most likely isolated. The easiest way to check for isolation is to change your voltmeter to it's ohm scale and measure the resistance between the two grounds. It is recommended that you turn both systems off prior to taking this resistance measurement. If the measured resistance is more than 100 Kohm, it's a fairly safe bet that your system has electrically isolated grounds.

3.1.5 Systems with Common Grounds

In the simplest (but perhaps least likely) case, your signal source will have the same ground as the CIO-DAS08-PGx. This would typically occur when providing power or excitation to your signal source directly from the board. There may be other common ground configurations, but it is important to note that any voltage between the board ground and your signal source ground is a potential error voltage if you set up your system based on a common ground assumption.

As a safe rule of thumb, if your signal source or sensor is not connected directly to an LIGND pin on your board, it's best to assume that you do not have a common ground even if your voltmeter measured 0.0 Volts. Configure your system as if there is ground offset voltage between the source and the board. This is especially true if you are using the board at high gains, since ground potentials in the sub millivolt range will be large enough to cause A/D errors, yet will not likely be measured by your handheld voltmeter.

3.1.6 Systems with Common Mode (ground offset) Voltages

The most frequently encountered grounding scenario involves grounds that are somehow connected, but have AC and/or DC offset voltages between the board and signal source grounds. This offset voltage may be AC, DC or both and may be caused by a wide array of phenomena including EMI pickup, resistive voltage drops in ground wiring and connections, etc. Ground offset voltage is a more appropriate term to describe this type of system, but since our goal is to keep things simple, and help you make appropriate connections, we'll stick with our somewhat loose usage of the phrase Common Mode.

3.1.7 Small Common Mode Voltages

If the voltage between the signal source ground and board ground is small, the combination of the ground voltage and input signal will not exceed the CIO-DAS800's +/-10V common mode range, (i.e. the voltage between grounds, added to the maximum input voltage, stays within +/-10V). This input is compatible with the CIO-DAS08-PGx and the system can be connected without additional signal conditioning. Fortunately, most systems will fall in this category and have a small voltage differential between grounds.

3.1.8 Large Common Mode Voltages

If the ground differential is large enough, the +/- 10V common mode range will be exceeded (i.e. the voltage between the board and signal source grounds, added to the maximum input voltage you're trying to measure exceeds +/-10V). In this case the board cannot be directly connected to the signal source. You will need to change your system grounding configuration or add isolation signal conditioning. (Please look at our ISO-RACK and ISO-5B-series products to add electrical isolation, or give our technical support group a call to discuss other options).

WARNING

Relying on the earth prong of a 120VAC for signal ground connections is not advised.. Different ground plugs may have large and potentially even dangerous voltage differentials. Remember that the ground pins on 120VAC outlets on different sides of the room may only be connected in the basement. This leaves the possibility that the "ground" pins may have a significant voltage differential (especially if the two 120 VAC outlets happen to be on different phases!)

3.1.9 Board and Signal Source Have Isolated Grounds

Some signal sources will already be electrically isolated from the board. Figure 3-4 shows a typical isolated ground system. These signal sources are often battery powered, or are fairly expensive pieces of equipment (since isolation can be expensive), isolated ground systems provide excellent performance, but require some extra effort during connections to assure optimum performance is obtained. Please refer to the following sections for further details.

3.2 WIRING CONFIGURATIONS

Combining all the grounding and input type possibilities provides us with the following potential connection configurations. The combinations along with our recommendations on usage are shown in Table 3-1 below.

Table 3-1. Analog Input Configuration Recommendations

GROUND CATEGORY	INPUT CONFIGURATION	OUR VIEW
Common Ground	Single-Ended Inputs	Recommended
Common Ground	Differential Inputs	Acceptable
Common Mode Voltage < +/-10V	Single-Ended Inputs	Not Recommended
Common Mode Voltage < +/-10V	Differential Inputs	Recommended
Common Mode Voltage > +/- 10V	Single-Ended Inputs	Unacceptable without adding Isolation
Common Mode Voltage > +/-10V	Differential Inputs	Unacceptable without adding Isolation
Already Isolated Grounds	Single-ended Inputs	Acceptable
Already Isolated Grounds	Differential Inputs	Recommended

The following sections depicts recommended input wiring schemes for each of the seven possible input configuration/grounding combinations.

3.2.1 Common Ground / Single-Ended Inputs

Single-ended is the recommended configuration for common ground connections. However, if some of your inputs are common ground and some are not, we recommend you use the differential mode. There is no performance penalty (other than loss of channels) for using a differential input to measure a common ground signal source. However the reverse is not true. Figure 3-4 below shows a recommended connection diagram for a common ground / single-ended input system.

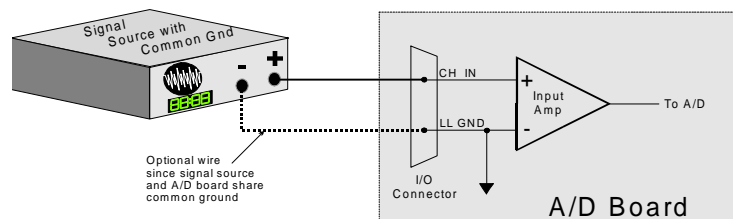

Signal source and A/D board sharing common ground connected to single-ended input.

Figure 3-4. Common Ground / Single-Ended Inputs

3.2.2 Common Ground / Differential Inputs

The use of differential inputs to monitor a signal source with a common ground is an acceptable configuration though it requires more wiring and offers fewer channels than selecting a single-ended configuration. Figure 3-5 below shows the recommended connections in this configuration.

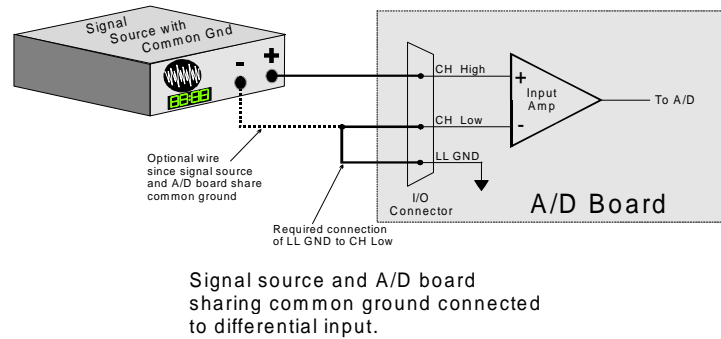

Figure 3-5. Common Ground / Differential Inputs

3.2.3 Common Mode Voltage < +/-10V/Single-Ended Inputs

This is not a recommended configuration. In fact, the phrase common mode has no meaning in a single-ended system and this case would be better described as a system with offset grounds. However, you can try this configuration. No system damage should occur and depending on the overall accuracy you require, you may receive acceptable results.

3.2.4 Common Mode Voltage < +/-10V/Differential Inputs

Systems with varying ground potentials should always be monitored in the differential mode. Care is required to assure that the sum of the input signal and the ground differential (referred to as the common mode voltage) does not exceed the common mode range of the A/D board (+/-10V on the CIO-DAS08-PGx). The diagram below show recommended connections in this configuration.

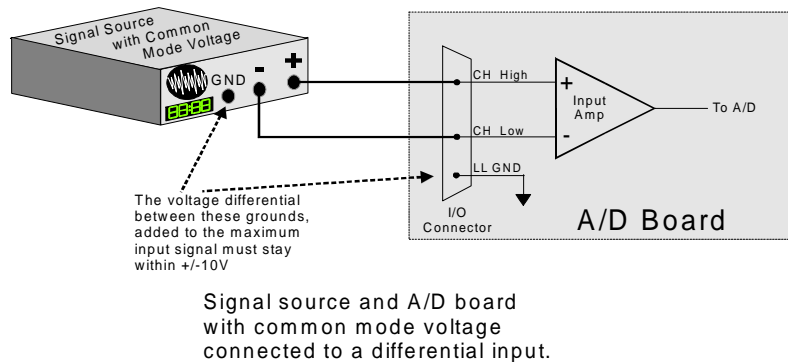
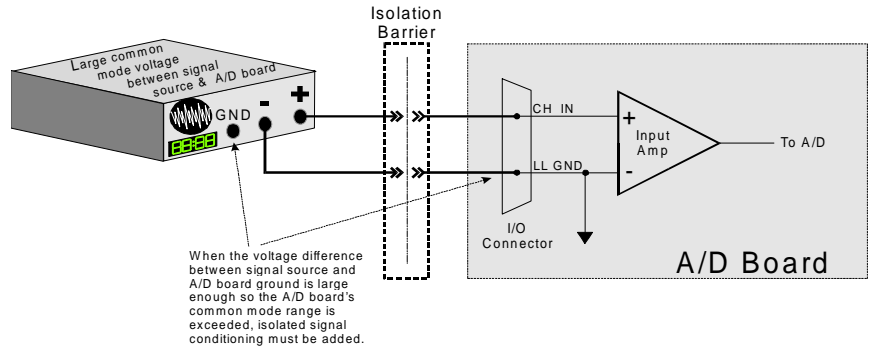

Figure 3-6. Common Mode Voltage < +/-10V/Differential Inputs

3.2.5 Common Mode Voltage > +/-10V

The CIO-DAS08-PGx will not directly monitor signals with common mode voltages greater than +/-10V. You will either need to alter the system ground configuration to reduce the overall common mode voltage, or add isolated signal conditioning between the source and your board. See Figures 3-7 and 3-8.



System with a Large Common Mode Voltage, Connected to a Single-Ended Input

Figure 3-7. Common Mode Voltage - >+/- 10V Single-Ended Input

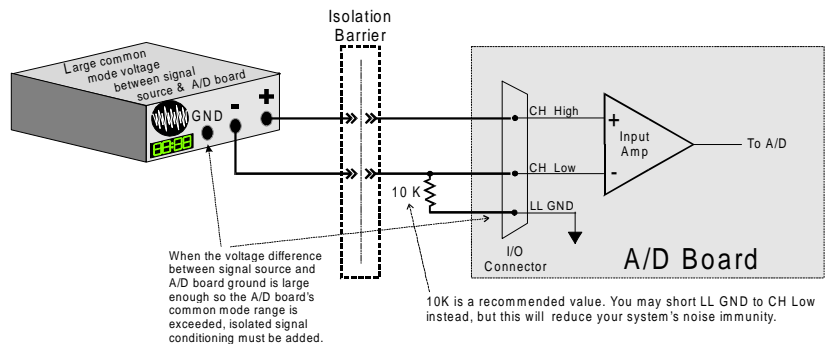

System with a Large Common Mode Voltage, Connected to a Differential Input

Figure 3-8. Common Mode Voltage - >+/- 10V Differential Input

3.2.6 Isolated Grounds / Single-Ended Inputs

Single-ended inputs can be used to monitor isolated inputs, though the use of the differential mode will increase your system's noise immunity. Figure 3-9 below shows the recommended connections in this configuration.

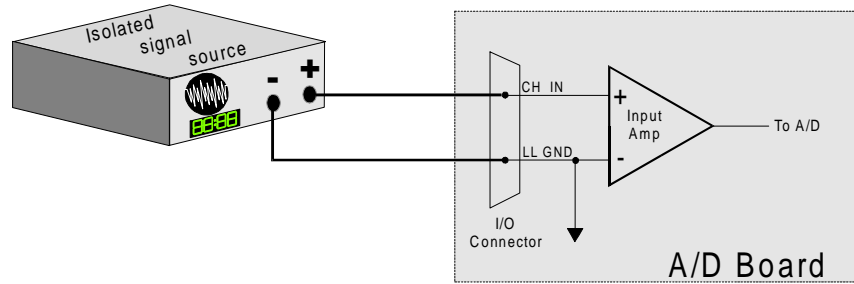

Isolated Signal Source
Connected to a Single-Ended Input

Figure 3-9 . Isolated Grounds - Single-Ended Inputs

3.2.7 Isolated Grounds / Differential Inputs

Optimum performance with isolated signal sources is assured with the use of the differential input setting. Figure 3-10 shows the recommended connections in this configuration.

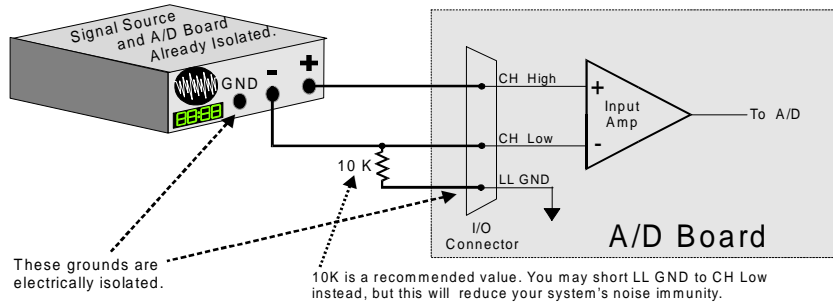

Already isolated signal source
and A/D board connected to
a differential input.

Figure 3-10. Isolated Grounds - Differential Inputs

4: REGISTER ARCHITECTURE

4.1 CONTROL & DATA REGISTERS

The CIO-DAS08-PGx is controlled and monitored by writing to and reading from eight consecutive 8-bit I/O addresses. The first address, or BASE ADDRESS, is determined by setting a bank of switches on the board.

Register manipulation is best left to experienced programmers as most of the possible functions are implemented in easy to use Universal Library™.

The register descriptions follow the format:

7	6	5	4	3	2	1	0
A/D1	A/D2	A/D3	A/D4	A/D5	A/D6	A/D7	A/D8

Where the numbers along the top row are the bit positions within the 8-bit byte and the numbers and symbols in the bottom row is the function associated with each bit.

To write to or read from a register in decimal or HEX, the bit weights listed in table 4-1 apply.

Table 4-1. Register Bit Weights

BIT POSITION	DECIMAL VALUE	HEX VALUE
0	1	1
1	2	2
2	4	4
3	8	8
4	16	10
5	32	20
6	64	40
7	128	80

To write control words or data to a register, the individual bits must be set to 0 or 1 then combined to form a byte.

The method of programming required to read/write bits from bytes is beyond the scope of this manual.

In summary form, the registers and their function are listed in Table 4-2. Each register has eight bits which may constitute a byte of data or eight individual bit read/write functions.

Table 4-2. Board Register Functions

ADDRESS	READ FUNCTION	WRITE FUNCTION
BASE	A/D Bits 9-12 (LSB)	Start 8 Bit A/D Conversion
BASE +1	A/D Bits 1(MSB)-8	Start 12 Bit A/D Conversion
BASE +2	EOC, IP1-IP3, IRQ, MUX Address	OP1-OP4, INTE & MUX Address
BASE +3	Channel MUX and Gain Status	Programmable Gain Control
BASE +4	Read Counter 0	Load Counter 0
BASE +5	Read Counter 1	Load Counter 1
BASE +6	Read Counter 2	Load Counter 2
BASE +7	Not Used	Counter Control

4.2 A/D DATA REGISTER

BASE ADDRESS (Read / Write)

7	6	5	4	3	2	1	0
A/D9	A/D10	A/D11	A/D12 LSB	0	0	0	0

READ

On read, it contains the least significant four digits of the analog input data.

These four bits of analog input data must be combined with the eight bits of analog input data in BASE + 1, forming a complete 12 bit number. The data is in the format 0 = minus full scale. 4095 = +FS.

WRITE

Writing any data to the register causes an immediate 8-bit A/D conversion.

BASE + 1 (Read / Write)

7	6	5	4	3	2	1	0
A/D1 MSB	A/D2	A/D3	A/D4	A/D5	A/D6	A/D7	A/D8

READ

On read, the most significant A/D byte is read.

The A/D Bits code corresponds to the voltage on the input according to the table below.

DECIMAL	HEX	BIPOLAR	UNIPOLAR
4095	FFF	+Full Scale	+Full Scale
2048	800	0 Volts	½ Full Scale
0	0	-Full Scale	0 Volts

WRITE

Writing to this register starts a 12-bit A/D conversion.

A note of caution: Place several NO-OP instructions between consecutive 12-bit A/D conversions to avoid over-running the A/D converter.

4.3 STATUS AND CONTROL REGISTER

BASE + 2 (Read / Write) Read Functions

7	6	5	4	3	2	1	0
EOC	IP3	IP2	IP1	IRQ	MUX2	MUX1	MUX0

READ = STATUS

EOC = 1 the A/D is busy converting and data should not be read.

EOC = 0 the A/D is not busy and data can be read.

IP3 to IP1 are the digital input lines on the 37 pin analog connector.

IRQ is the status of an edge triggered latch connected to Interrupt Input (pin 24) of the analog connector. It is high (1) when a positive edge has been detected. It can be reset to 0 by writing to the INTE mask at BASE + 2 write.

MUX 2 to MUX 0 is the current multiplexer channel. The current channel is a binary coded number between 0 and 7 .

WRITE = CONTROL

BASE + 2 (Read / Write) Write Functions

7	6	5	4	3	2	1	0
OP4	OP3	OP2	OP1	INTE	MUX2	MUX1	MUX0

OP4 to OP1 are the digital output lines on the 37 pin analog connector.

INTE = 1 enables interrupts (positive edge triggered) onto the PC bus IRQ selected via the IRQ jumper on the CIO-DAS08-PGA.

INTE = 0 disables the passing of the interrupt detected at pin 24 to the PC bus.

IRQ is set to 1 every time an interrupt occurs. If you want to process successive interrupts then set INTE = 1 as the last step in your interrupt service routine.

MUX2 to MUX0. Set the current channel address by writing a binary coded number between 0 and 7 to these three bits.

NOTE

Every write to this register sets the current A/D channel MUX setting to the number in bits 2-0.

4.4 PROGRAMMABLE GAIN REGISTER

The register's layout when written to is :

BASE + 3 (Read / Write) Write Functions

BIT 7	BIT 6	BIT 5	BIT 4	BIT 3	BIT 2	BIT 1	BIT 0
X	X	X	X	R3	R2	R1	R0

The register's layout when read from is :

BASE + 3 (Read / Write) Read Functions

BIT 7	BIT 6	BIT 5	BIT 4	BIT 3	BIT 2	BIT 1	BIT 0
X	MA2	MA1	MA0	R3	R2	R1	R0

The gain/range of a board is controlled by writing a control code to the register. The codes are as follows:

BI-POLAR CIO-DAS08-PGH		CONTROL CODES					
GAIN	RANGE V	DEC	HEX	R3	R2	R1	R0
0.5	± 10.0	8	8	1	0	0	0
1	± 5.0	0	0	0	0	0	0
5	± 1.0	10	A	1	0	1	0
10	± 0.5	2	2	0	0	1	0
50	± 0.1	12	C	1	1	0	0
100	± 0.05	4	4	0	1	0	0
500	± 0.01	14	E	1	1	1	0
1000	± 0.005	6	6	0	1	1	0

UNI-POLAR CIO-DAS08-PGH		CONTROL CODES					
GAIN	RANGE V	DEC	HEX	R3	R2	R1	R0
1	0 to 10.0	1	1	0	0	0	1
10	0 to 1.0	3	3	0	0	1	1
100	0 to 0.1	5	5	0	1	0	1
1,000	0 to 0.01	7	7	0	1	1	1

There are fewer ranges available for the CIO-DAS08-PGL. Gains of 2, 4 & 8 are often called binary gains. These ranges are not available on the MetraByte DAS-8PGA.

BI-POLAR CIO-DAS08-PGL		CONTROL CODES					
GAIN	RANGE V	DEC	HEX	R3	R2	R1	R0
0.5	±10.0	8	8	1	0	0	0
1	±5.0	0	0	0	0	0	0
2	±2.5	2	2	0	0	1	0
4	±1.25	4	4	0	4	0	0
8	±0.625	6	6	0	1	1	0

UNI-POLAR CIO-DAS08-PGL		CONTROL CODES					
GAIN	RANGE V	DEC	HEX	R3	R2	R1	R0
1	0 to 10.0	1	1	0	0	0	1
2	0 to 5.0	3	3	0	0	1	1
4	0 to 2.5	5	5	0	1	0	1
8	0 to 1.25	7	7	0	0	1	1

BI-POLAR CIO-DAS08-PGM		CONTROL CODES					
GAIN	RANGE V	DEC	HEX	R3	R2	R1	R0
0.5	±10.0	8	8	1	0	0	0
1	±5.0	0	0	0	0	0	0
2	±0.5	10	A	1	0	1	0
4	±0.05	12	C	1	1	0	0
8	±0.01	14	E	1	1	1	0

UNI-POLAR CIO-DAS08-PGM		CONTROL CODES					
GAIN	RANGE V	DEC	HEX	R3	R2	R1	R0
1	0 to 10.0	9	9	1	0	0	1
2	0 to 1.0	11	B	1	0	1	1
4	0 to 0.1	13	D	0	1	0	1
8	0 to 0.01	15	F	1	1	1	1

To set the input range of the CIO-DAS08-PGx board, select the desired range from the table and write the code in decimal or hexadecimal to base address + 3. Here is an example in BASIC:

```
100 OUT &H303, 8 'Set gain = 0.5 (±10V range)
```

The range of the analog inputs is now set to ±10V or 2.44mV per bit (10/4096).

MA2 to MA0 = Indicates the analog input channel that is currently selected (by writing to base +2).

4.5 COUNTER LOAD & READ REGISTERS

COUNTER 0

BASE ADDRESS + 4 (Read / Write)

7	6	5	4	3	2	1	0
D7	D6	D5	D4	D3	D2	D1	D0

COUNTER 1

BASE ADDRESS + 5 (Read / Write)

7	6	5	4	3	2	1	0
D7	D6	D5	D4	D3	D2	D1	D0

COUNTER 2

BASE ADDRESS + 6 (Read / Write)

7	6	5	4	3	2	1	0
D7	D6	D5	D4	D3	D2	D1	D0

The data in the counter read register, and the action taken on the data in a counter load register, is wholly dependent upon the control code written to the control register.

The counters are 16-bit counters, each with an 8-bit window, the read / load register. Data is shifted into and out of the 16-bit counters through these 8-bit windows according to the control byte.

You will need an 8254 data sheet if you want to program the 8254 directly at the register level.

4.6 COUNTER CONTROL REGISTER

BASE ADDRESS + 7 (Write Only)

7	6	5	4	3	2	1	0
SC1	SC0	RL1	RL0	M2	M1	M0	BCD

WRITE

SC1 to SC0 are the counter select bits. They are binary coded between 0 and 2.

RL1 to RL0 are the read and load control bits:

RL1	RL0	OPERATION
0	0	Latch Counter
0	1	Read/load high byte
1	0	Read/load low byte
1	1	Read/load low the high byte (word transfer)

M2 to M0 are the counter control operation type bits:

M2	M1	M0	OPERATION TYPE
0	0	0	Change on terminal count
0	0	1	Programmable one-shot
0	1	0	Rate generator
0	1	1	Square wave generator
1	0	0	Software triggered strobe
1	0	1	Hardware triggered strobe

BCD = 0 then counter data is 16-bit binary. (65,535 max)

BCD = 1 then counter data is 4-decade Binary Coded Decimal. (9,999 max)

4.7 COUNTER/TIMER

The 82C54 counter/timer chip (Figure 4-1) may be used for event counting, frequency and pulse measurement and as a pacer clock for the A/D converter. All the inputs, outputs and gates of the counter are accessible through the 37 pin analog connector with the exception of the counter 2 input.

The counter is easy to understand. The GATE line determines whether or not TTL level pulses present at the CLK input will decrement the counter. The OUT line then transitions (pulses or shifts) depending on the codes in the control register and the count value in the count register.

The counter gates, inputs and outputs are all simple TTL.

The primary purpose of the counter timer chip is to pace the A/D samples. The input of counter 2 is jumper selectable for a crystal controlled source or the PC bus clock source.

The PCLK signal is divided by 2 prior to the input at counter 2, therefore, if the PCLK signal on your PC/AT were 8 MHz, the signal at the input of counter 2 would be 4MHz. The 10 MHz crystal source is divided by 10.

Assuming a 4 MHz signal at counter 2, the rates out of counter 2 (pin 6) can vary between 2 MHz (4 MHz / 2) to 61 Hz (4 MHz / 65,535). For rates slower than 61 Hz, wire the output of counter 2 to the input of counter 1. Next, wire the output of counter 1 to the interrupt input (pin 24). The slowest rate is then once every 17 minutes.

When using the crystal source, the minimum rate would be about 15 Hz using only one counter.

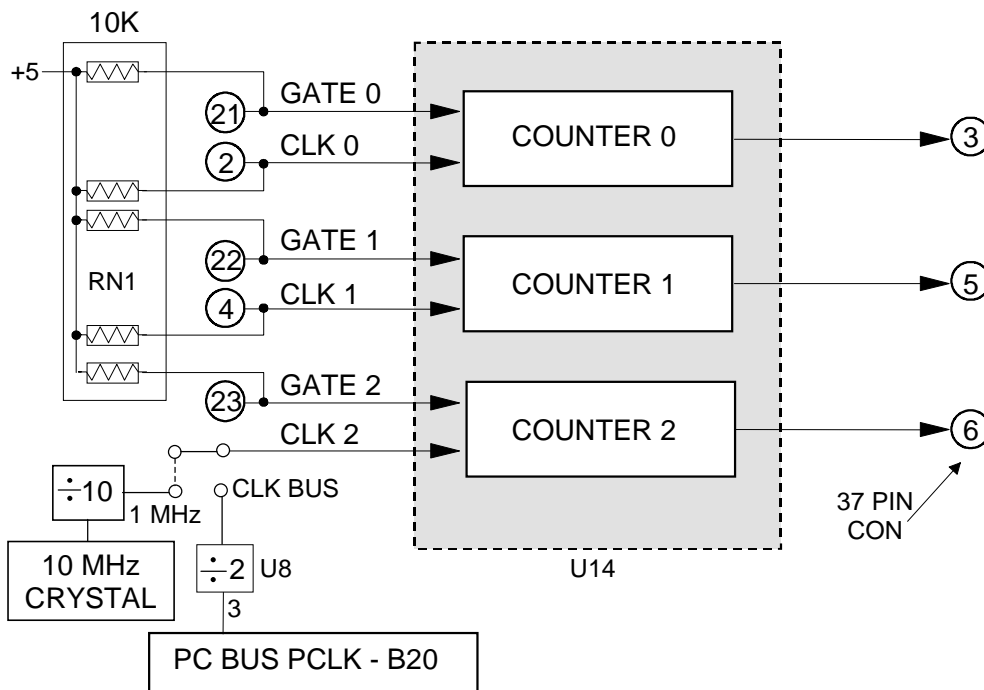

Figure 4-1. Counter /Timer Block Diagram

4.8 DIGITAL INPUT

The digital inputs are simple TTL level lines. They feed into an 8-bit register which has other on-board signals fed into it. The resultant 8-bit status byte can be read at BASE address + 2.

The digital inputs IP1, IP2 & IP3 can be used as status lines to trigger or hold off A/D conversions. Be aware of possible conflicts when pacing conversions from the on - board pacer and simultaneously using IP1 through IP3 as general purpose digital inputs.

4.9 DIGITAL OUTPUT

The digital output lines, OP1, OP2, OP3 & OP4 are TTL level lines which are controlled with part of an 8-bit register located at BASE address + 2.

The lines are used to control the multiplexer address on an external CIO-EXP32 differential amplifier/ multiplexer if one is installed. For that reason, we recommend not using them as general purpose digital outputs.

4.10 TRIGGER & INTERRUPT LOGIC

The trigger logic on the CIO-DAS08-PGx is quite simple. Pin 24 of the 37 pin connector is an input to a flip-flop which can be read at BASE address + 2 on the IRQ bit. The board can be triggered by polling this bit until a trigger pulse (rising edge) has occurred. It must be reset by a write to BASE + 2 before it will respond to additional rising edges.

By writing a 1 to the INTE control bit at BASE + 2, the rising edge detected by the flip-flop will be translated into an interrupt pulse which can be used to interrupt the CPU's 8259 interrupt controller on the PC motherboard.

The interrupt level jumper on the board may need to be installed. Move it from the 'X' (default) position to the IRQ number you want the interrupt pulse on.

The 82C54 counter/timer chip is primarily a pacer for A/D samples. It is an integral part of the trigger logic. To employ the 82C54 as an A/D pacer, wire the output of the counter (pin 6) that you will program to provide pacing pulses directly into the Interrupt Input (pin 24).

5: SPECIFICATIONS

Power consumption

+5V: 900 mA typical, 1125 mA max

Analog input section

A/D converter type	AD574
Resolution	12 bits
Number of channels	8 differential (configurable as quasi-differential via installation of SIP resistor)
Input Ranges	
CIO-DAS08/PGH	$\pm 10V, \pm 5V, \pm 1V, \pm 0.5V, \pm 0.1V, \pm 0.05V, \pm 0.01V, \pm 0.005V, 0$ to 10V, 0 to 1V, 0 to 0.1V, 0 to 0.01V software selectable
CIO-DAS08/PGL	$\pm 10V, \pm 5V, \pm 2.5V, \pm 1.25V, \pm 0.625V, 0$ to 10V, 0 to 5V, 0 to 2.5V, 0 to 1.25V software selectable
CIO-DAS08/PGM	$\pm 10V, \pm 5V, \pm 0.5V, \pm 0.05V, \pm 0.01V, 0$ to 10V, 0 to 1V, 0 to 0.1V, 0 to 0.01V software selectable
Polarity	Unipolar/Bipolar, software selectable
A/D pacing	Internal counter or external source (Interrupt Input, jumper selectable, rising edge) or software polled
A/D Trigger sources	External hardware/software (Digital In 1)
Data transfer	Interrupt or software polled
DMA	None
A/D conversion time	25 μ s
Throughput	20 kHz, PC dependent
Accuracy	$\pm 0.01\%$ of reading ± 1 LSB $\pm 0.05\%$ of full scale
Differential Linearity error	± 1 LSB
Integral Linearity error	± 0.5 LSB
No missing codes guaranteed	12 bits
Gain drift (A/D specs)	± 25 ppm/ $^{\circ}$ C
Zero drift (A/D specs)	$\pm 10\mu$ V/ $^{\circ}$ C
Common Mode Range	$\pm 10V$
CMRR	72 dB
Input leakage current (@25 Deg C)	100 nA
Input impedance	10 Meg Ohms min
Absolute maximum input voltage	± 35

Digital Input / Output

Digital Type (main connector)	
Output:	74LS273
Input:	74LS244
Configuration	4 fixed output bits, 3 fixed input bits
Number of channels	4 out, 3 in
Output High	2.7 volts min @ -0.4 mA
Output Low	0.4 volts max @ 8 mA
Input High	2.0 volts min, 7 volts absolute max
Input Low	0.8 volts max, -0.5 volts absolute min
Interrupts	2 - 7, jumper selectable
Interrupt enable	Programmable
Interrupt sources	External (Interrupt In), rising edge

Counter section

Counter type	82C54
Configuration	3 down-counters, 16 bits each
	Counter 0 - independent, user configurable
	Source: user connector (Counter 0 In)
	Gate: user connector (Gate 0)
	Output: user connector (Counter 0 Out)
	Counter 1 - independent, user configurable
	Source: user connector (Counter 1 In)
	Gate: user connector (Gate 1)
	Output: user connector (Counter 1 Out)
	Counter 2 - independent, user configurable
	Source: 1 MHz (from 10MHz Xtal via divide-by-ten) or PC SysClk (via divide by 2 circuit) selectable by jumper
	Gate: user connector (Gate 2)
	Output: user connector (Counter 2 Out)
Clock input frequency	10 Mhz max
High pulse width (clock input)	30 ns min
Low pulse width (clock input)	50 ns min
Gate width high	50 ns min
Gate width low	50 ns min
Input low voltage	0.8V max
Input high voltage	2.0V min
Output low voltage	0.4V max
Output high voltage	3.0V min

Environmental

Operating temperature range	0 to 50°C
Storage temperature range	-20 to 70°C
Humidity	0 to 95% non-condensing

EC Declaration of Conformity

We, Measurement Computing Corp., declare under sole responsibility that the product:

CIO-DAS08-PGx

Part Number

Description

to which this declaration relates, meets the essential requirements, is in conformity with, and CE marking has been applied according to the relevant EC Directives listed below using the relevant section of the following EC standards and other normative documents:

EU EMC Directive 89/336/EEC: Essential requirements relating to electromagnetic compatibility.

EU 55022 Class B: Limits and methods of measurements of radio interference characteristics of information technology equipment.

EN 50082-1: EC generic immunity requirements.

IEC 801-2: Electrostatic discharge requirements for industrial process measurement and control equipment.

IEC 801-3: Radiated electromagnetic field requirements for industrial process measurements and control equipment.

IEC 801-4: Electrically fast transients for industrial process measurement and control equipment.

Carl Haapaoja, Director of Quality Assurance

Measurement Computing Corporation
16 Commerce Boulevard,
Middleboro, Massachusetts 02346
(508) 946-5100
Fax: (508) 946-9500
E-mail: info@measurementcomputing.com
www.measurementcomputing.com